

TILLINGHAST, DAN C TILLINGHAST, AMY

4158 BENSON-HARDEE RD
2000158987

PLAT: / UNIQ ID 459648
ID NO: 162100-48-6285

Parcel ID: 07-D-06-036-B-

SPLIT FROM ID

Reval Year: 2019 Tax Year: 2019
Appraised By on 07/30/2010 00119 RURAL ACREAGE

COUNTY TAX (100), W JOHNSTON F/D (100)
TURLINGTON 162100-77

CARD NO. 1 of 1
1.500 AC
TW-07 CI- FR-36

SRC= Estimated
AT- LAST ACTION 20180814

CONSTRUCTION DETAIL			
Foundation	3		
Continuous Footing	5.00		
Sub Floor System	5		
Wood	10.00		
Exterior Walls	10		
Aluminum/Vinyl Siding	30.00		
Roofing Structure	03		
Gable	8.00		
Roofing Cover	12		
Metal Prefinished	8.00		
Interior Wall Construction	2		
Wall Board or Wood Wall	12.00		
Interior Wall Construction	4		
Plywood Panel	0.00		
Interior Floor Cover	09		
Pine	4.00		
Heating Fuel	03		
Gas	1.00		
Heating Type	04		
Forced Air - Ducted	4.00		
Air Conditioning Type	03		
Central	4.00		
Bedrooms/Bathrooms/Half-Bathrooms	2/1/0	7.000	
Bedrooms	BAS - 1 FUS - 1 LL - 0		
Bathrooms	BAS - 1 FUS - 0 LL - 0		
TOTAL POINT VALUE	93.000		
BUILDING ADJUSTMENTS			
Quality	3	C	1.00
Shape/Design	2	MARKET FACTOR 1.02	1.02
Size	Size	Size	0.98
TOTAL ADJUSTMENT FACTOR 1.000			
TOTAL QUALITY INDEX 93			

MARKET VALUE										DEPRECIATION		CORRELATION OF VALUE	
USE	MOD	Eff. Area	QUAL	BASE RATE	RCN	EYB	AYB			NORM	0.42000	CREDENCE TO MARKET	
01	01	2,006	93	72.54	149215	1977	1837	% GOOD			58.0		

TYPE: SINGLE FAMILY RESIDENTIAL
STYLE: 3 - 2.0 Stories
Single Family Residential

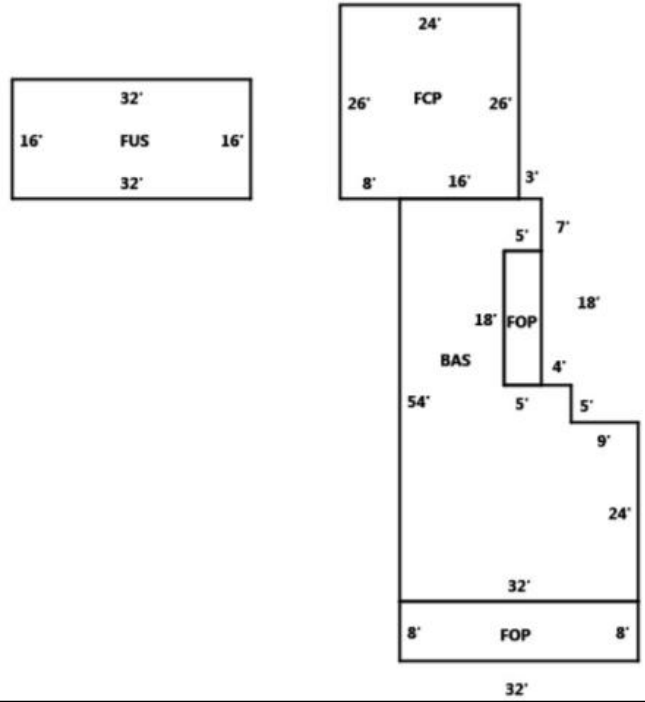

PRIOR				PERMIT				
BUILDING VALUE	OBXF VALUE	LAND VALUE	PRESENT USE VALUE	DEFERRED VALUE	TOTAL VALUE	CODE	DATE	NO.
71,500	6,960	30,380	0	0	108,840			
ROUT: WTRSHD:								
SALES DATA								
OFF. RECORD BOOK	DATE PAGE	MO	YR	DEED TYPE	O/U	V/I	INDICATE SALES PRICE	
03980	0218	5	2011	WD	I	I	110,000	
03699	0063	5	2009	WD	Q	I	110,000	
03630	0354	12	2008	SO	X	I	50,000	
03257	0787	12	2006	WD	X	I	240,000	
00880	0418	1	1980	WD	U	V	17550	
HEATED AREA 1,780								
NOTES								

SUBAREA										ORIG % COND	BLDG #	AYB	EYB	DEP SCH	OVR	% COND	OB/XF DEPR. VALUE	
TYPE	GS AREA	PCT	RPL CS	CODE	DESCRIPTION	COUNT	LTH	WTH	UNITS	UNIT PRICE								
BAS	1,268	100	91981	01	STORAGE		20	12	240	14.00	100.00	1	2017	2017	S3		94	3160
FCP	624	025	11316	17	SHED		10	12	120	6.50	100.00	1	1970	1970	S5		30	230
FOP	346	035	8777	06	CARPORT		24	26	624	9.00	100.00	1	1980	1980	S5		30	1690
FUS	512	090	33441	43	BARN		60	20	1,200	15.10	100.00	1	1950	1950	S3		30	5440
FIREPLACE	4 - 2.5 or more			3,700	06	CARPORT		20	20	400	9.00	1	2017	2017	S5		90	3240
SUBAREA TOTALS	2,750		149,215	10A	ASPH PAVIN		0	0	6,500	3.00	0.00	1	2017	2017	S5		90	17550
TOTAL OB/XF VALUE																		31310

BLDG DIMENSIONS | BAS=S54E32N24W9N5W4W5N18E5N7W3W16Area:1268;FOP=S8E32N8W32Area:256;FOP=N18W5S18E5Area:90;FUS=N16W32S16E32Area:512;FCP=N26W24S26E8E16Area:624;TotalArea:2750

LAND INFORMATION																	
HIGHEST AND BEST USE	USE CODE	LOCAL ZONING	FRONTAGE	DEPTH	DEPTH / SIZE	LND MOD	COND FACT	OTHER ADJ/NOTES RF AC LC TO OT	ROAD TYPE	LAND UNIT PRICE	TOTAL LAND UNITS	UNIT TYPE	TOTAL ADJST	ADJUSTED UNIT PRICE	LAND VALUE	OVERRIDE VALUE	LAND NOTES
RES HOMESITE PAVED	0200	RAG	0	0	0.9000	0	1.0000			28,500.00	1.500	AC	0.900	25,650.00	38475	0	
TOTAL MARKET LAND DATA															38475		
TOTAL PRESENT USE DATA																	